

MagicTube Compact

BCS449 S

Mounting instructions



Type number	LEDs QTY	Power	Voltage	Beam angle	CCT/Color	Control method	Max. No. per DMX universe	
BCS449 S 0.3m Mono	24 LED	5W	24V DC	OC	2700K 3000K 4000K 5000K 6500K	ON-OFF DMX	512 (Only DMX versions) (Тільки версії DMX) (Тек DMX нұсқалары) (Только версии DMX) (仅DMX型号)	0.24
BCS449 S 0.5m Mono	36 LED	7.5W						0.4
BCS449 S 1m Mono	72 LED	15W						0.8
BCS449 S 0.3m RGB	24 LED	5W			RGB	DMX	170	0.24
BCS449 S 0.5m RGB	36 LED	7.5W						0.4
BCS449 S 1m RGB	72 LED	15W						0.8
BCS449 S 0.3m RGBW	48 LED	5W			RGB27K RGB30K RGB40K RGB50K RGB65K	DMX	128	0.24
BCS449 S 0.5m RGBW	72 LED	7.5W						0.4
BCS449 S 1m RGBW	144 LED	15W						0.8
BCS449 S 0.3m tW	36 LED	5W			2700K+6500K	DMX	256	0.24
BCS449 S 0.5m tW	72 LED	7.5W						0.4
BCS449 S 1m tW	144 LED	15W						0.8

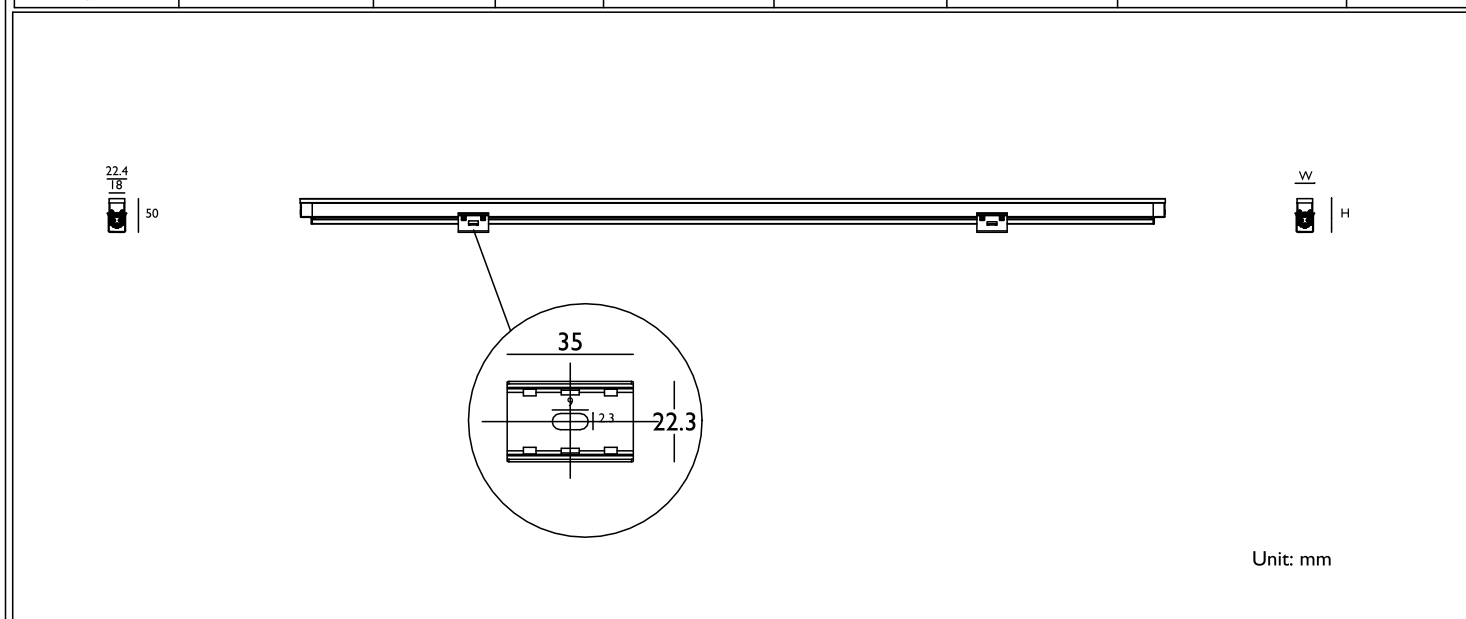

Signify (China) Investment Co., Ltd.
 Building No. 9, Lane 888 Tianlin Road,
 Minhang District, Shanghai, China
 Postalcode: 200233

LiteMagic

1

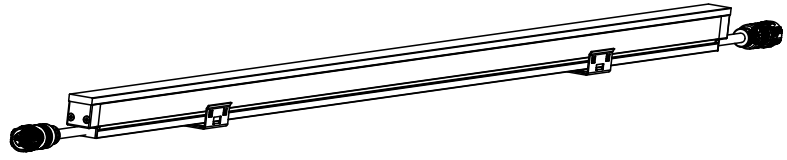
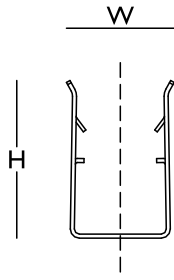

2

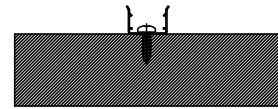
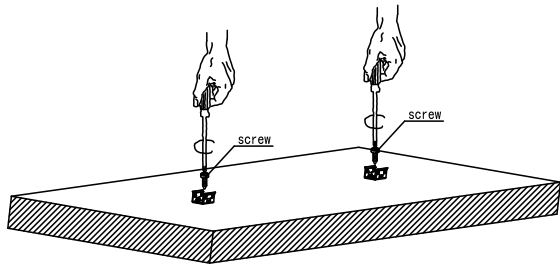
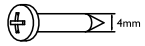

3

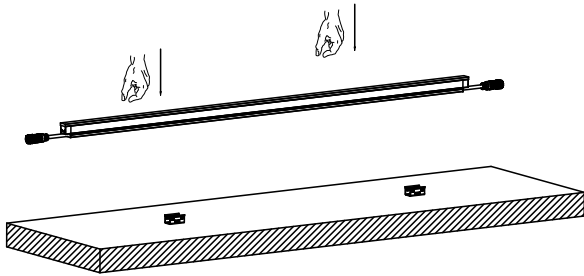

4

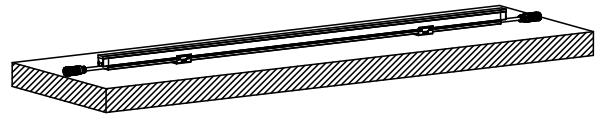

5

space between A and B > 2mm

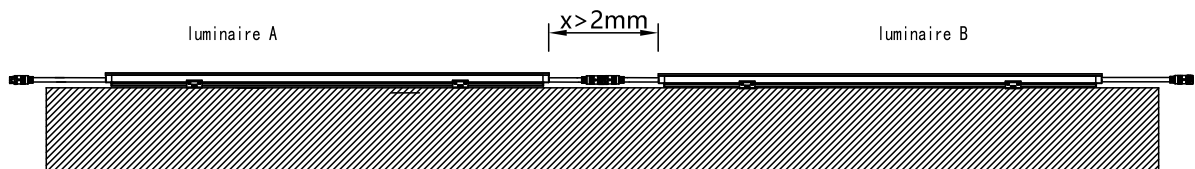

A Wiring diagram of On/Off versions

EN

⚠ Input with male waterproof connector

2-pin male connector

If needed, luminaires can be connected through 2m-length 2-pole jump cables completed with 1 pair of male and female connectors, which should be ordered separately by client.

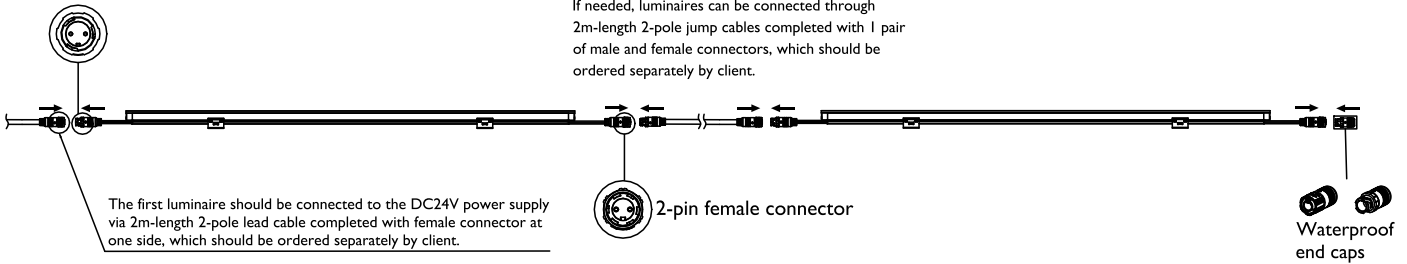

Recommended driver models

I2NC	Description	Max. No. of interconnection luminaires		
		5W	7.5W	15W
929001485580	LED Transformer 150W 24V 220-240V	24	16	8
929001485680	LED Transformer 300W 24V 220-240V	29	19	9

Dock the waterproof connectors up

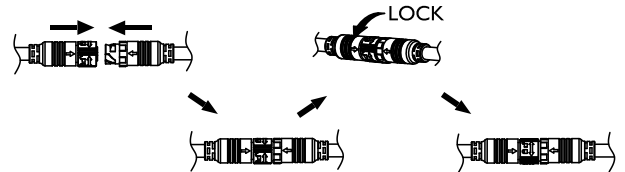

1. When used in a humid environment, please seal all entries to prevent liquid ingress. Please use RTV silicone and waterproof junction box.
2. Wiring method depends on local electrical standards and regulations, generally using threaded and screwable wire connectors or screw terminal blocks.
3. Waterproof end cap should be installed on the connectors in the ends which are not docked up.

B Wiring diagram of DMX versions

⚠ Input with male waterproof connector

5-pin male connector

5-pin female connector

Y-shaped connector with 1 pair of 5-pin male and female connectors, which should be ordered separately by client

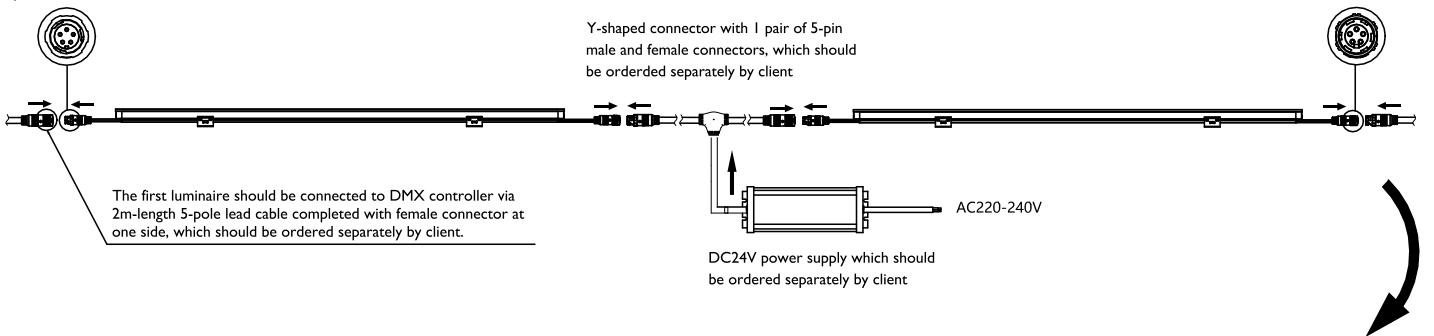

If needed, luminaires can be connected through 2m-length 5-pole jump cables completed with 1 pair of male and female connectors, which should be ordered separately by client.

Waterproof end caps



1. For wet or damp locations seal all points of entry to prevent water infiltration. Use RTV silicone and weatherproof junction boxes.
2. The wire connection method is determined by local electrical codes and regulations, typically either wire nuts or screw terminal blocks.
3. Maximum DMX data run from DMX source to the last luminaire is 100m or maximum 64 luminaires unless booster or repeater is used. With each ZXP399 DMX amplifier applied, the DMX data can be repeated for up to 100m or maximum 64 luminaires. Maximum no. of controlled luminaires refer to table in Page 1. The controller with output DMX signal as SELV is recommended.
4. The controller selected for this luminaire must meet the following conditions: the controller signal output terminal can pass 48V withstand voltage test, the same dimmer is only used for this type of luminaire, and can not be mixed with other dimming type luminaires.
5. Waterproof end cap should be installed on the connectors in the ends which are not docked up.



1. Ensure that main power supply is off before installing or wiring a luminaire.
2. Do not attempt to install or use a luminaire until you read and understand the installation instructions and safety labels.
3. Do not hot swap luminaires.
4. Ensure that power to the series is off before connecting or disconnecting individual luminaires.
5. The luminaire shall, under no circumstance, be covered with insulating material of any kind.
6. Do not use a luminaire for any voltage for which it is not rated. Do not exceed the specified voltage and current input for any luminaire.
7. Do not use a luminaire if the glass, housing, or power cables are damaged.
8. The luminaire power and data cables are not replaceable. If the external cables are damaged, the lighting luminaire needs to be replaced.
9. The luminaire' LEDs is not replaceable. The complete luminaire should be replaced when LEDs' lifetime reaches to the end.
10. The luminaire should be positioned so that prolonged staring into the luminaire at a distance closer than 26m is not expected .

Warning

1. The luminaire shall be installed by a qualified electrician and wired in accordance with the latest IEEE electrical regulations or the national requirements.
2. Turn power off before inspection, installation or removal.
3. The light source contained in this luminaire shall only be replaced by the manufacturer or his service agent or a similar qualified person.
4. Refer to technical datasheet for additional electrical properties to ensure safe installation.
5. Luminaire installed must not be in contact with combustible materials.
6. Ensure power supply cables (D+ / D-) are connected correctly before switching on.

Maintenance

1. Ensure power supply is switched off before attempting any maintenance work.
2. Periodic cleaning of the luminaire optical lens cover will ensure maximum optical efficiency.
3. Luminaire optical lens cover shall be cleaned with clean water and non-abrasive soap, cleaner or detergent solution.

Caution

The Luminaire must be used within the applicable product specifications, installation instructions and environmental conditions for storage & operations according to application guidelines provided by Signify for product Warranty to be valid.

توصيل الأسلاك

قم بإيقاف تشغيل الطاقة قبل الفحص أو التركيب أو الفصل .
يجب تركيب الفانوس من قبل فني مؤهل يتبع التعليمات الموضحة
يرجى قراءة ورقة البيانات التقنية لمعرفة المواصفات الكهربائية للتأكد من التركيب الآمن يجب أن
يكون كل من التركيب و التوصيل متوافقا مع أنظمة IEEE و المواصفات المحلية يجب تغيير مصدر
عدم تركيب أو وضع الفانوس بالقرب
من مواد قابلة للاشتعال الإضاءة فقط عن طريق الجهة المصنعة أو مقدم خدمات مؤهل.
عدم تمدد كابل الطاقة بالقرب من مواد ذات حرارة عالية
لتأكيد القطبية الصحيحة تأكد من توصيل الأسلاك بشكل صحيح
هذا الفانوس مصنع للاستخدام الخارجي

الصيانة

تأكد من فصل الطاقة قبل إتمام عملية الصيانة
استمرار تنظيف الناشتر يؤكد الحصول على إضاءة شديدة
يجب تنظيف غطاء الناشتر بالماء و صابون ناعم أو محلول مطهر

احذر

فضلا تأكد من ملاءمة تعليمات التركيب و ظروف البيئة للتخزين و التشغيل لاستمرار ضمان المنتج